

# ***HT-101***

Manual Crimp Hand Tool  
For Jumbo PV Contacts AWG 18-20  
User's Manual



[www.foehrenbach.be](http://www.foehrenbach.be)

# 1. Operation

## 1.1. Crimping instructions

To Load Terminal:

1. Insert terminal, (as shown0 with "U" shaped barrels up and "BOX" end first into terminal holder until the "BOX" end of the terminal hits the stop spring.
2. Squeeze handle until it clicks once to "CAPTURE" terminal.

To Load Wire:

1. Insert wire to proper depth
2. While holding wire, squeeze handle until tool automatically opens when released. The terminal will then be fully crimped.
3. Gently pull wire straight out to remove crimped assembly.

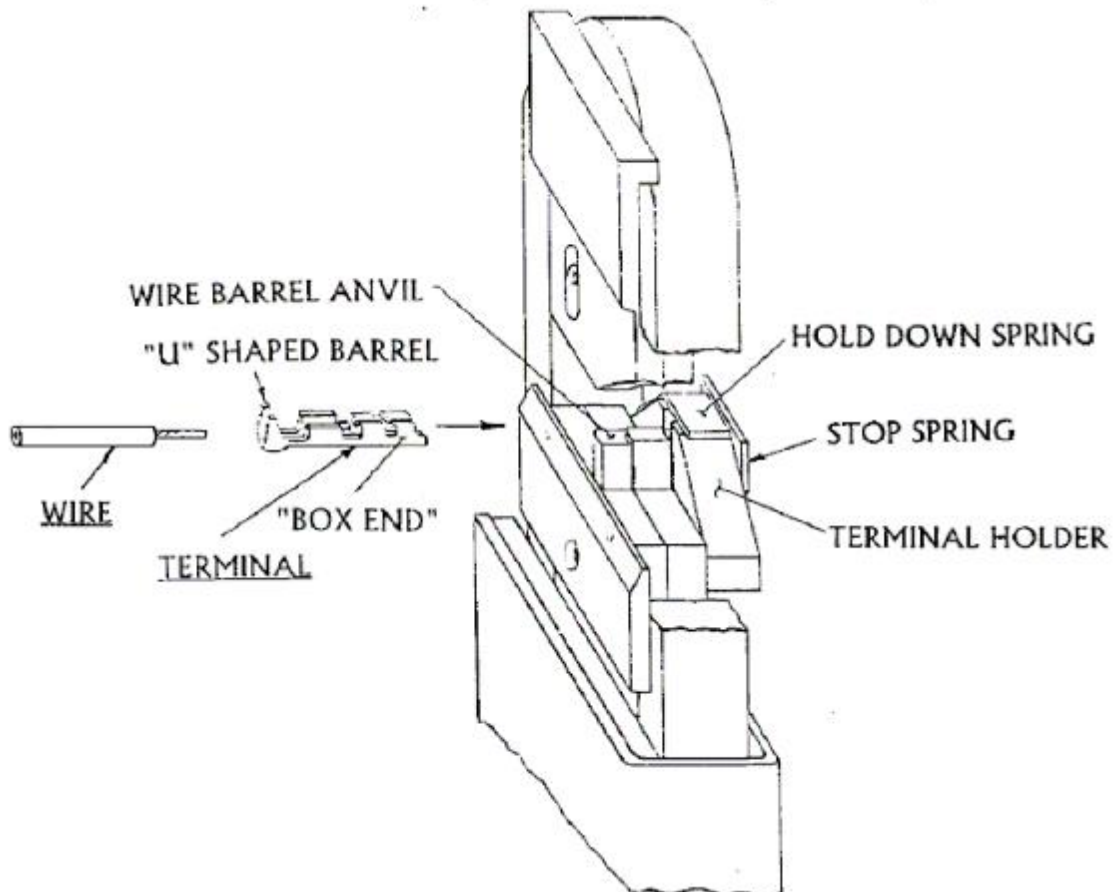

## 2. Spare Parts

HT-0101 – Wire Size 18 – 20

Detail No.	Description	Part no
1.	Hand tool Crimper holder	A105614-1
2.	Insulation Support Crimper	A-1113-8
3.	Wire Barrel Crimper	A-105617-1
4.	Hand tool Anvil Holder	A-858-4
5.	Insulation Support Anvil	A-1114-7
6.	Wire barrel Anvil	A-105618-1
7.	Terminal Holder	A-107945-1
8.	Stop Spring	A-1176
9.	Hold down Spring	A-1241
10.	Knob	A-1170
11.	Cam	A-1169
12.	Lock Screw	A-1117-2

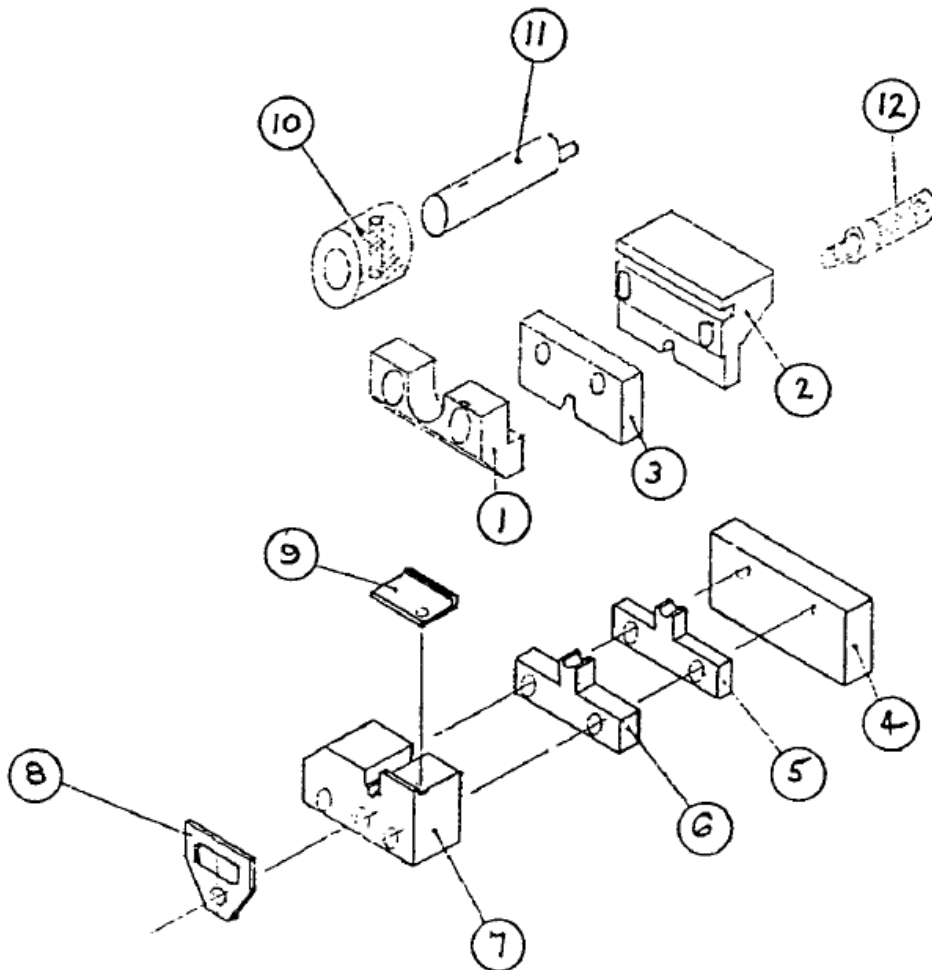

### **3. Service**

- For any support, please contact Föhrenbach Application Tooling:

Föhrenbach Application Tooling  
Krijgsbaan 128  
B – 2640 Mortsel  
Belgium

Tel : +32 (0)3 216 19 98  
Fax : +32 (0)3 216 15 07  
e-mail : [application.tooling@foehrenbach.be](mailto:application.tooling@foehrenbach.be)  
Website : [www.foehrenbach.be](http://www.foehrenbach.be)

### **4. Warranty**

Please refer to our Terms and Conditions of Sale.

The technical data in this publication has been carefully checked and assembled. No liability from inaccuracies or errors is assumed.  
The right to change or improve this document without notice is reserved.