

HT251
Handpistol for AWG 26-30
User's Guide

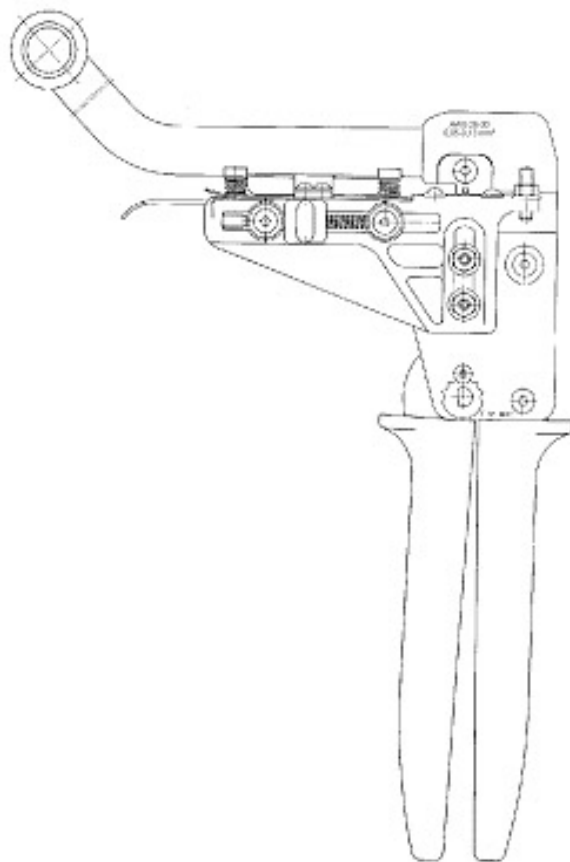

www.foehrenbach.be

CONTENTS

1. DESCRIPTION.....	3
1.1 Operating instructions.....	3
2. SPECIFICATION.....	4
2.1 Product information	4
3. ADJUSTMENTS.....	4
3.1 Adjustment of the crimp height	4
3.2 Adjustment of feed track unit	4
3.3 Adjustment of the feeding	4
3.4 Adjustment of cutter plate	4
3.5 Adjustment of terminal position	4
4. MAINTENANCE.....	4
5. PARTS.....	6
5.1 Parts for figure 1.....	6
5.2 Parts for figure 2.....	7

1. DESCRIPTION

The handtool HT 251 is designed to crimp Dubox terminals with small reel in the wire range AWG 26-30.

The terminals are guided in a feed track, fed with hand (yellow lever), positioned in crimp tooling and crimped. During the crimp action the Dubox terminal is cut off from the carrier strip.

1.1 Operating instructions

1. Place the handtool in your left hand, so that the movable handle (item 11, figure 1) may be actuated by your thumb.
2. Actuate with the right hand the yellow lever (item 6, figure 2) which feeds the Dubox terminal into the crimping area.
3. Use wire which is stripped over a length of 2.75 ± 0.25 mm and put the end of this wire against the box of the product.
4. Place the wire into the bowl of the terminal so that the end of the wire touches the wire stop.
5. Close the handtool by moving the handle (item 11, figure 1) while the wire is held in position.
6. When the handtool is completely closed, the movable handle (item 11, figure 1) may be returned to its starting position.
7. Finally take the crimped terminal from the handtool.

Note: The handtool has stops, which prevents opening the tool before the crimp action is completed. Should it be necessary, the stop can be released by turning the ratchet wheel at the back of the tool in the direction indicated by the two yellow arrows. Keep the movable handle under light pressure during this operation.

- Föhrenbach Application Tooling nv. – Krijgsbaan 128 – 2640 Mortsel - Belgium
- Tel.: +32 (0)3 216 19 98 Fax: +32 (0)3 216 15 07

2. SPECIFICATIONS

2.1 Product information

- Dubox
- Wire range AWG 26-30, 0.05 - 0.13 mm²
- Crimp height 0.63 - 0.70 mm
.0250 - .0275 inches
- Adjusted crimp height by manufacturer _____ mm

3. ADJUSTMENTS

3.1 Adjustments of crimp height

Eventually, the tool hinges can wear, so that the crimp height must be readjusted (see below specified height).

This is done by loosening the screw (item 21, figure 1) and rotating the stop rings (item 20, figure 1) one stop to change the crimp height approximately 0.05 mm (0.002 inches).

3.2 Adjustment of feed track unit (see figure 2)

CAUTION: No adjustments should be made with screw (item 21), nut (item 22) and with screw (item 23).

3.3 Adjustment of feeding

Loosen screws (item 13) and turn screw (item 27) to the left for further feeding of terminal and to the right for less feeding. The fed terminal must lay above the anvil. Tighten screw (item 13) after adjustment.

3.4 Adjustment of cutter plate

Loosen screws (item 18) and place cutter plate (item 19) against the anvil. Tighten screws (item 18) after adjustment.

Note:

- 1) During adjustment handtool must be in closed position.
- 2) When closing handtool (without terminal), the cutter plate may not move up.

3.5 Adjustment of terminal position:

Loosen screws (item 18) and adjust terminal positioner (item 17) so that the feed finger locates the terminals through the pilot holes. Tighten screws (item 18) after adjustment.

Note:

- 1) The terminal positioner may not damage the insulation barrel or wire barrel of terminal.
- 2) This adjustment may affect the bellmouth of the terminal.

4. MAINTENANCE

- Regular checks must be made for possible gold build-up on crimper and anvil.
- If necessary, these parts may be cleaned.
- Damaged parts must be replaced immediately. For part numbers see parts list.

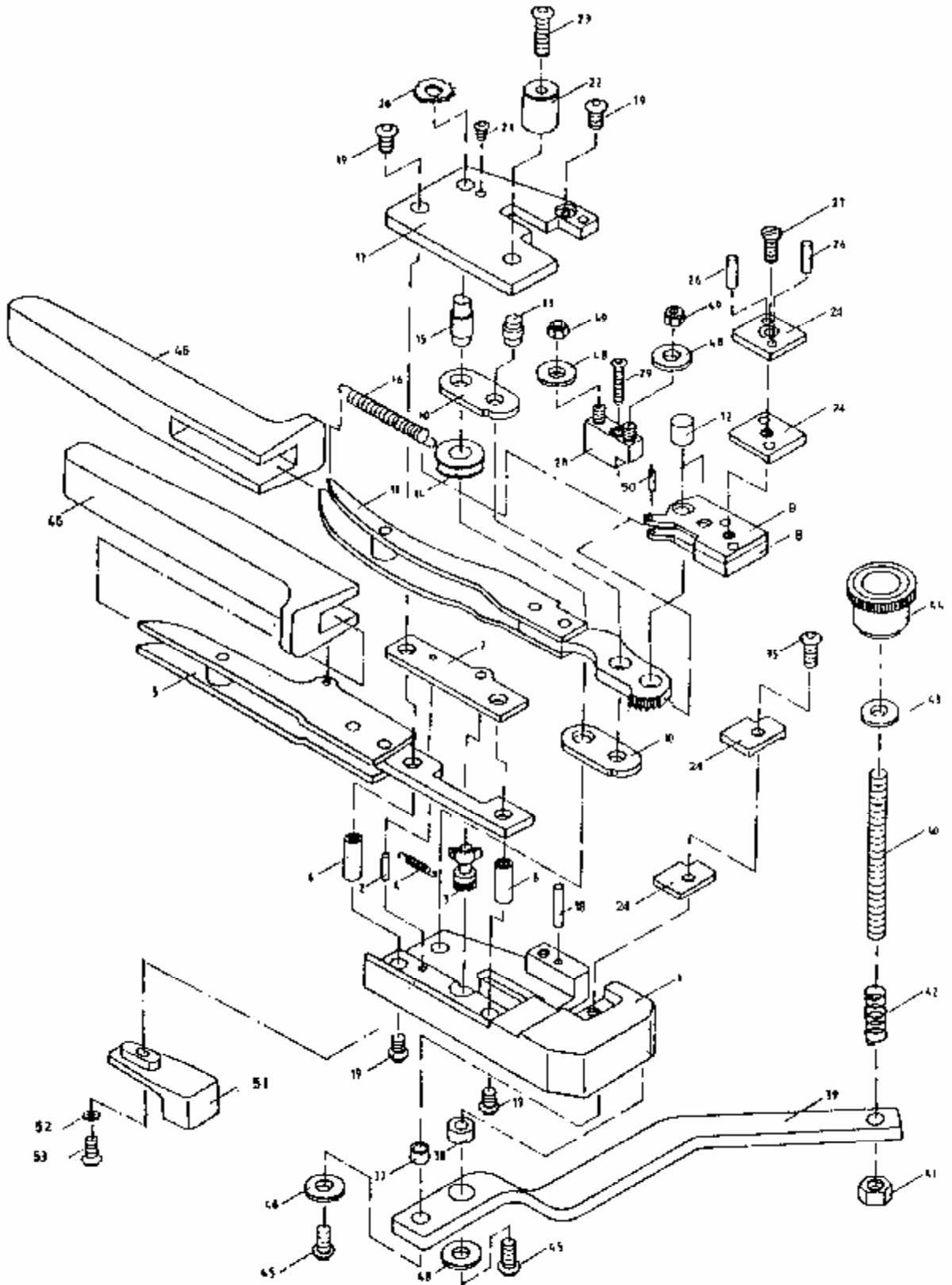

Figure 1

5. PARTS

5.1 Parts for figure 1

item no	part No	description	qty per assy
1	180998	Housing	1
2	5315-001-002	Dowel pin \varnothing 2 x 9,7	1
3	172391	Pawl	1
4	172392	Extension spring No 19	1
5	180999	Handle, permanent	1
6	172397	Connecting pin	2
7	181000	Spacer plate	1
8	181001	Retainer	1
9	181002	Retainer coverplate	1
10	181003	Connecting plate	2
11	181004	Handle, mobile	1
12	181005	Shaft	1
13	172388	Hinge pin	1
14	190583	Stop roll	1
15	181006	Eccentric pin	1
16	172394 A	Extension spring No 35	1
17	181007	Cover plate	1
18	5315-001-009	Dowel pin \varnothing 3m6 x 12	1
19	5305-003-006	But. hd. cap screw M4 x 7	4
20	190582	Stopping	1
21	5305-003-050	But. hd. cap screw M3 x 4	1
22	191623	Feeding stop	1
23	5305-003-009	But. hd. cap screw M4 x 16	1
24	181031	Crimp unit	1
26	5315-001-008	Dowel pin \varnothing 3m6 x 10	2
27	5305-004-008	Hex. soc. c'sink hd screw M4 x 10	1
28	181008	Guiding block	1
29	5305-001-017	Soc. hd. cap screw M3 x 12	1
35	5305-003-009	But. hd. cap screw M4 x 14	1
37	181009	Bushing \varnothing 6	1
38	181010	Bushing \varnothing 8	1
39	191607	Reelbracket	1
40	191608	Rod end M6	1
41	5310-001-006	Hex nut M6 Din 934	1
42	191609	Compression spring No 59	1
43	5305-035-003	Washer 6,0 Din 1440	1
44	191610	Special nut M6	1
45	5305-003-008	But. hd. cap screw M4 x 12	2
46	181011	Plastic grip	2
48	191593	Washer \varnothing 4,2 x 12 x 1,5	4
49	181012	Nut M4 Din 985	2
50	172393	Pin \varnothing 2 x 7,2	1
51	181013	Stop	1
52	5310-007-003	Washer \varnothing 3,2 x 7	1
53	5305-003-003	But. hd. cap screw M3 x 10	1

5.2 Parts for figure 2

item no	part No	description	qty per assy
1	181014	Feed track	1
2	191591	Distance plate	2
3	191592	Stop pin	1
4	191593	Washer \varnothing 4.2x12x1.5	5
5	191594	Feed finger pivot	1
6	181015	Feed lever	1
7	181016	Rond end M3	1
8	191597	Compression spring	1
9	181017	Feed finger	1
10	191599	Jaw finger spring No 60	1
11	191600	Stop screw	1
12	181018	Terminal guide	1
13	5305-003-051	Button head cap screw M4x5	3
14	181019	Feed track cover	1
15	181020	Compression spring No 129	2
16	191604	Spring holder screw	2
17	181021	Terminal positioner	1
18	5305-003-050	Button head cap screw M3x4	4
19	181022	Cutter plate	1
20	191614	Carrier strip guiding plate	1
21	5305-007-013	Socket set screw M4x15	1
22	5310-002-002	Hexagonal nut M4 DIN 934	1
23	5305-007-010	Socket set screw M4x8 Din916	1
24	5305-003-051	Button head cap screw M4x6	2
25	181023	Knurled screw M4 x 16 Din 653	
26	5305-007-010	Socket set screw M4x8	1
27	5305-007-062	Socket set screw M4x20	1
28	180983	Stop bushing	1
29	180984	Distance plate	1
	190115	Key for crimp height adjustment	1
	190116	Upper Pin wrench 2 mm	1
	190117	Pin wrench 2.5 mm	1

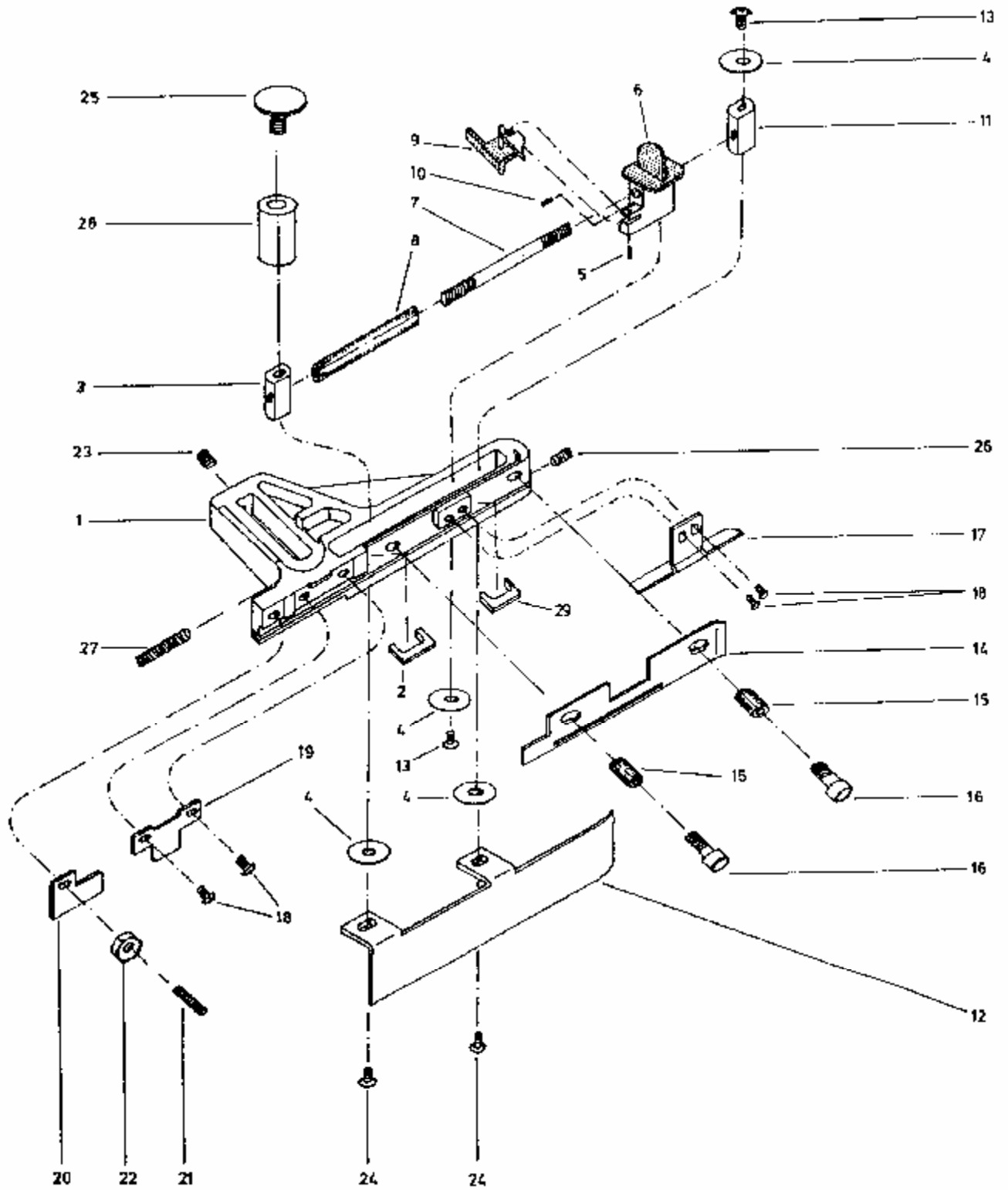

Figure 2